

Digital 16 Inputs DC 24 V RIO 16I xx

Profibus-DP • Interbus • CAN DeviceNet • CANopen

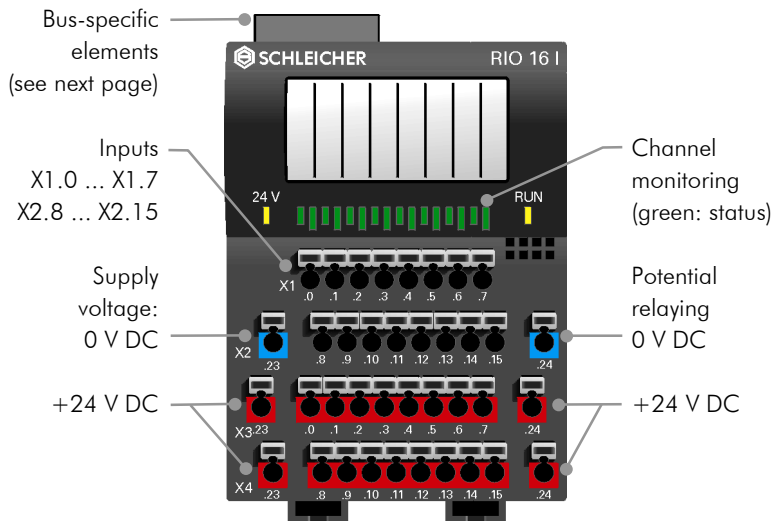

Block diagram

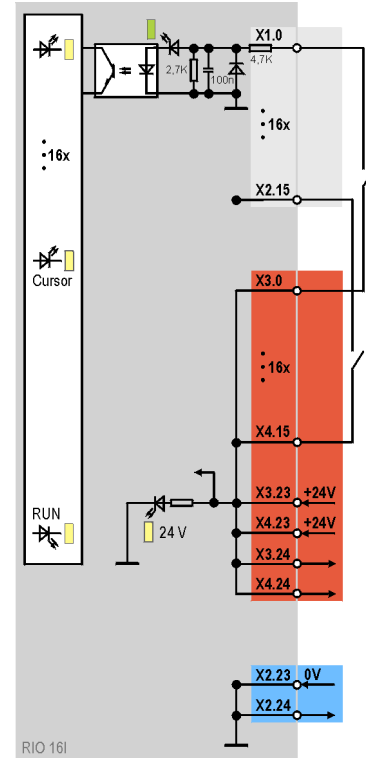

The RIO 16I xx digital compact module provides 16 input channels for binary DC signals with 24 V level. The integrated bus coupler connects the module to Profibus-DP, InterBus, CAN DeviceNet or CANopen field buses. The field bus, module and channel statuses are signalled by LEDs. Additional jumper levels can be created with the pluggable terminal extension.

Technical Data	RIO 16I DP	IBS	CAN DN	CANopen
Article number	362 141 08	362 141 09	362 141 11	362 155 00
Field bus	Profibus-DP	Interbus	CAN DeviceNet	CANopen
Number of inputs/outputs	16 inputs binary			
External supply voltage	DC 24 V ($\pm 20\%$, max. 5% residual ripple)			
Data width	1 bit per channel I/O			
Connection system	Two-wire (with RIO KE 16 terminal extension: four-wire)			
Inputs				
Switching level	H level +15 ... +30 V L level -30 ... +5 V			
Input current	Min. H level (+15V): $I \geq 2.5$ mA Max. L level (+5V): $I \leq 0.7$ mA Typ. (+24 V): $I = 4.5$ mA			
Isolation	Each channel individually isolated from internal bus by optocouplers			
Signal delay	Typical 100 μ s (hardware)			
For general technical data see last page				

General Module Structure

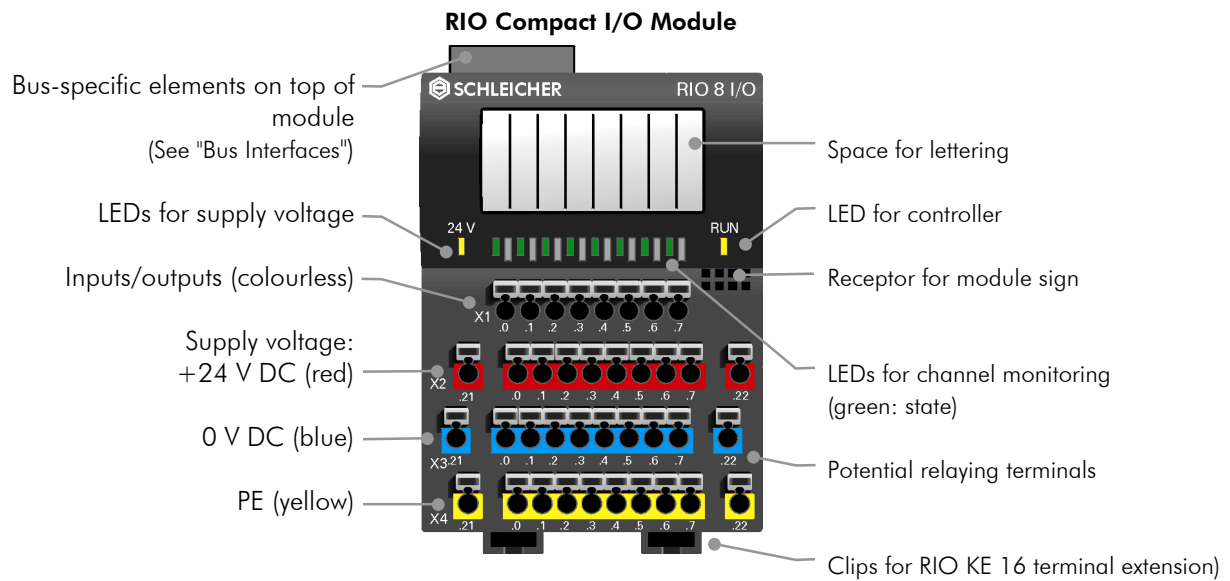

Bus Interfaces

All the field bus-specific connections and controls are on the top of the compact module housing

- ▶ Terminals/connectors for field bus connection
- ▶ Setting switches for module address, baud rate and module diagnosis
- ▶ LEDs for simple field bus diagnosis

Profibus-DP

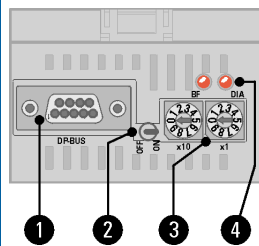

Bus connection

- 1 Subminiature, 9-pin, socket connector

Settings

- 3 Rotary switch for slave address, address range 0 ... 99
- 2 Toggle switch for logical shut-off of station
Set baud rate up to 12 MBaud automatic

Displays

- 4 Field bus diagnosis

Interbus

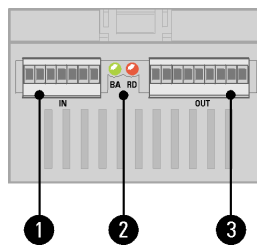

- 1 Screw terminal, 6-pole, input
- 3 Screw terminal, 8-pole, output

Baud rate fixed 500 Kbaud

- 2 Field bus diagnosis

CAN DeviceNet

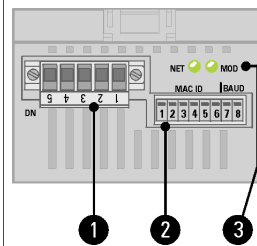

- 1 Open style connector 5-pin

- 2 DIP switches for
 - MAC-ID (address range 0 ... 63)
 - Baud rate (up to 500 Kbaud)

- 3 Field bus diagnosis

CANopen

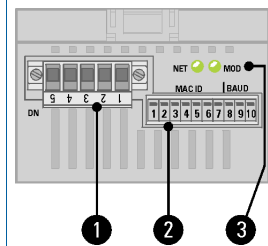

- 1 Open style connector 5-pin

- 2 DIP switches for
 - MAC-ID (address range 0 ... 127)
 - Baud rate (up to 1000 Kbaud)

- 3 Field bus diagnosis

Technical Data RIO IP20

Electrical data

Supply voltage	24 V DC \pm 20% max. 5% residual ripple
----------------	---

Connection system

Sensors / actuators	Spring terminal
Field bus	Profibus-DP: Subminiature, 9-pin
Supply voltage	Interbus: Screw terminals
	CAN DeviceNet / CANopen: Open style connector
	Spring terminal
Cable cross-section	Finely stranded 0.14 – 1.5 mm ² , single-core 0.5 – 2.5 mm ²

Housing and installation

Type of protection	IP 20 to EN 60529
Dimensions (W x H x D)	RIO microLine PLC: 74.5 x 93 x 51 mm
	RIO BC Bus Couplers: 74.5 x 93 x 51 mm
	RIO EC Bus Couplers: 63 x 93 x 51 mm
	RIO Expansion Modules: 69 x 93 x 51 mm
	RIO Compact I/Os: 69 x 93 x 51 mm
	RIO Terminal Extensions: 69 x 36 x 45 mm
Rail	DIN rail EN 50022-35
Installation position	Vertical, free air circulation

Climatic Conditions

Ambient operating temperature	0 ... +55°C (category KV to DIN 40040)
Storage temperature	-25 ... +70°C (category HS to DIN 40040)
Relative humidity	30 ... 95% (category F to DIN 40040), no condensation
Air pressure in operation	860 ... 1060 hPa

Mechanical strength

Vibration	10 ... 57 Hz constant amplitude 0.075 mm
	57 ... 150 Hz constant acceleration 1 g (to DIN IEC 68-2-6)

Electromagnetic compatibility

Electrostatic discharge	EN 61000-4-2: 4 kV contact discharge
Electromagnetic fields	EN 61000-4-3: field intensity 10 V/m, 80 ... 1000 MHz
Burst	EN 61000-4-4: 2 kV on DC supply lines, 1 kV on I/O signal and serial interface lines
Interference emissions	EN 55011: Limit Category A, Group 1